



MAKROFON M75F/260-370 ZVE(E)(H)

General Features

The ZÖLLNER MAKROFON M75F is a diaphragm sound transmitter operating on compressed air. The signal is released by an electromagnet or manually using a hand pull-rope. To avoid the costly laying of a pull-rope, a second electromagnet for emergency voltage can be provided. A thermostat controlled anticondensation heating keeps the sound horn and the operating valve free from condensed water and thus from ice. Typically the MAKROFON M75F will operate on air pressures between 6 and 40 bar. For electric release and operation of the heating a connection to AC 1phase or 24 V DC power supply is required.

Essentials

- » full compliance with the Colregs 1972 Annex III
- » type approved by all wellknown international authorities and classification societies
- » application:
 - » vessels of class II (M75F/260), 75 m but less than 200 m in length
 - » vessels of class III (M75F/370 and M75F/260), 20 m but less than 75 m in length
 - » land alarm, i.e. bunker stations, oil refineries, airports, power plants, factories
- » compressed air requirement: 6-40 bar free, dry air (carbonic acid etc. may also be used)
- » system voltage: AC 1phase or 24 V DC

Advantages

- » decades of experience
- » best material and workmanship - made in Germany
- » entirely made of best non-corrosion, seawater resistant materials
- » sound horn made of sheet-copper (not plastic!)
- » simple but matured design, almost maintenance-free
- » easy exchange of all parts with onboard tools
- » easy installation: - relatively low weight

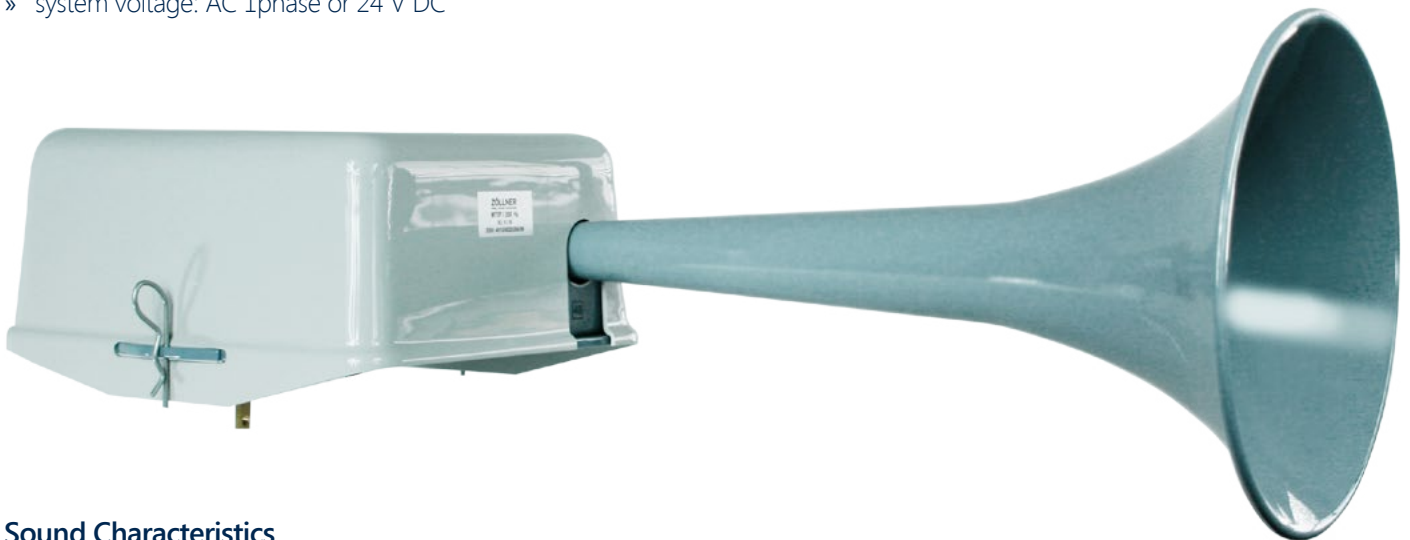

Sound Characteristics

- » broad frequency spectrum with many higher harmonics
- » signals with strong over tones for best penetration of background noise level. Even when a background noise covers the actual basic frequency the residual tone forms a parent frequency in the human hearing. Two or three harmonics are sufficient for the hearing to perceive the basic frequency.
- » sound frequency of 260 / 370 Hz very advantageously ranks in the lower admissible range (class II 130-350 Hz class III 250-700 Hz)
- » sound pressure level
 - » (M75F/260): 138 dB in 1/3rd-octave band level at 1 m distance
 - » (M75F/370): 130 dB in 1/3rd-octave band level at 1 m distance

Positioning and installation

Positioning as high as practicable on the vessel to reduce interception of the emitted sound by obstructions and to avoid hearing damage risk to the personnel. The sound pressure level of a vessel's own signal at listening posts must not exceed 110 dB(A). Installation - compressed air supply pipe preferably of copper with a filter (type F3.1) preceding the Makrofon operating valve. Supply pipe must be free from any dirt particles and moisture.

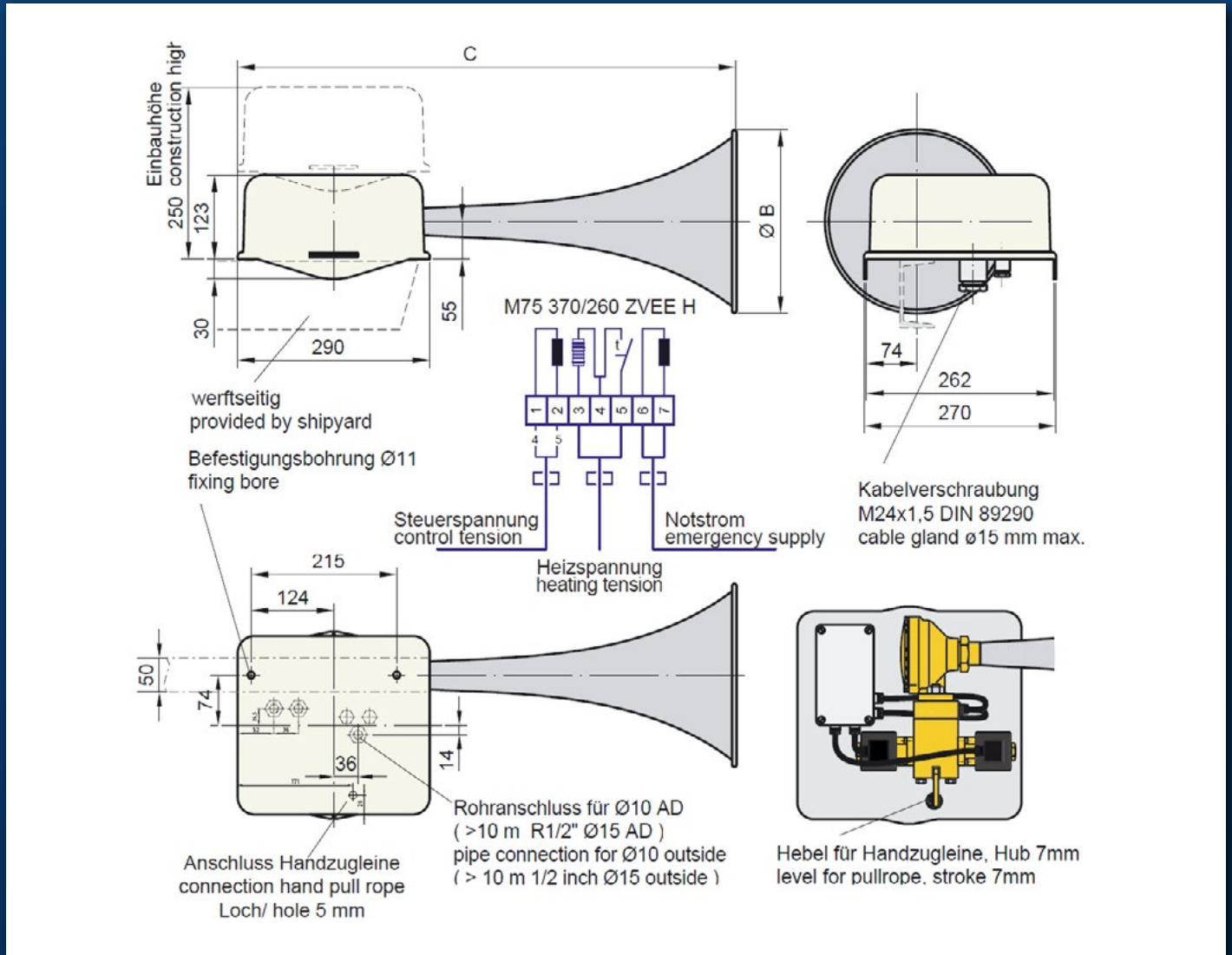

type	ship length [m]	fundamental frequency [Hz]	sound intensity in 1/3rd-octave band level at 1 m distance		air pressure [bar]	air consumption free, dry air l/sec	air pipe connection [mm]	cable gland [mm]	system voltage	heating [W]	dimensions [mm]		approx. weight [kg]	type approval dB BSH(DHI) no.
			dB(A)	min. IMO 1/3rd oct							B	C		
M75/370	20-<75	370	132	130	6-40	8-12	10x1	ø15 max.	AC 1phase or 24 V DC	100	200	560	8	4615/6021100/09
M75/260	75-<200	260	138	138							268	730		8
	20-<75													